



THE ALZHEIMER  
SOCIETY *of* IRELAND

# November Activity Pack





Dear Friends,

As the winter months roll in many of us take pleasure from curling up in front of the fire, or with a blanket, and enjoying a good book.

Books have the ability to transport us to different worlds, see different lives, experience new cultures and ideas and can be a fantastic way to relax – either reading to ourselves or having a loved one read to us. As such, this month's theme is all about "Books and Reading".

We have some bookmarks for you to cut out and gift, games for you to enjoy and, of course, stories and poems for you to read.

If you would like to suggest a theme for a pack, or if you'd like to share your writings with us and have it featured on our social media please let us know. We welcome poems and stories to be included in the pack if we have any artists or writers out there! Please contact Danielle at [danielle.keogh@alzheimer.ie](mailto:danielle.keogh@alzheimer.ie) if you'd like to contribute.



***"Stories create community, enable us to see through the eyes of other people, and open us to the claims of others."***

***– Peter Forbes***

## Useful Resources:



THE ALZHEIMER  
SOCIETY of IRELAND

- Our Free Helpline is available at: **1800 341 341**
- 50808 text service: 50808 provides a safe space where you're listened to by a trained Crisis Volunteer. You'll text back and forth, only sharing what you feel comfortable with. **Text the word "hello" to 50808 to begin.**
- We are hosting several Virtual Cafes. They are a place to come together, share a cuppa and listen to our amazing guest speakers. For information on how to attend visit:  
<https://alzheimer.ie/service/alzheimer-cafe/>
- The ASI also have a huge library of factsheets and resources available on: <https://alzheimer.ie/get-support/resources-and-factsheets/>
- M4D Radio is a 24/7 online radio station with songs specifically picked to evoke memories and aid reminiscence. To find out more and to listen, please visit: <https://m4dradio.com/>
- Contact ALONE if you have concerns about your own wellbeing, or the wellbeing of an older person you know. Their National Support Line is available seven days a week from 8am – 8pm on **0818 222 024**
- Emergency Response Numbers: **999 or 112**
- HSE 24/7 Your Mental Health Information Helpline: **1800 111 888**

## Table of Contents

<b><u>Activity</u></b>	<b><u>Pages</u></b>
Imagination Spot the Difference	<b>5</b>
Relaxing Read Spot the Difference	<b>6</b>
Literary Jigsaw	<b>7</b>
The Blessed Poet Folktale	<b>8 - 9</b>
An Irish Account of Reading	<b>10 – 11</b>
Find and Count Game	<b>11</b>
Pictures to Colour	<b>12 – 19</b>
Nostalgic Number Ones	<b>20</b>
Bookmarks	<b>21</b>
Cailín na Gaillimhe	<b>22</b>
I Opened a Book	<b>23</b>
Read to Me	<b>24</b>
Clancy's Wooden Wedding	<b>25 - 26</b>
Genre Jumble	<b>27</b>
The Meeting of the Waters	<b>28</b>

## Imagination Spot the Difference

See if you can see the 5 differences between these two pictures



## Relaxing Read Spot the Difference

See if you can see the 5 differences between these two pictures



## Literary Jigsaw

Cut out and rearrange the pieces below to create the image to the right

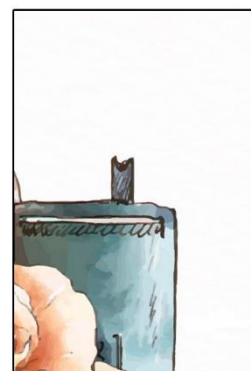

## The Blessed Poet

### A Folktale by Philomena and Margaret Smith

About a hundred years ago there was a man named James Martin who lived at Millrosh, Oldcastle in Co Meath. At that time there was no Parochial House in Oldcastle and the Clergy lived at Millbrook about a mile from the town. This man Martin used to work as a labourer for the neighbouring people very often for the Priest whose name was Father Leonard. The story is told that one evening when Martin was after hay-making he lay down beside a bale of hay to rest himself and have some ease. After some time he fell asleep and when he awoke he saw beside him a pair of boots, a fiddle, and a book. Martin stretched his hand for the book and as he did something hit him in the eye which made him permanently blind in one eye. Everything disappeared and he was immediately full of learning and for the first time in his life he could read and write.

Up till this time, he was illiterate. It was thought that a fairy or some spirit had touched him with a wand. He had at once started to compose and write of a very beautiful type. Some of his writings are still to be found. "The wounded soldier" is a excellent piece of his composition describing the battle of Waterloo. He was married but had no family and he used to call his wife Sweet Jane of Loughcrew. Another song that won fame for him was "Sweet Lough Bawn." There are some pieces of his writings to be found and this one ran thus:

"Sweet Drumone that stands alone.  
An ancient village-town  
There's neither fair nor market there

Since Cromwell he called round  
The bonny lark from dawn till dark  
Still whistles at the dawn.  
With her long beak if she could speak  
Good morning Sweet Lough Bawn."



## Reading – An Irish Account from 1938

“Reading is one of the most enjoyable pastimes one can find. In the present age the need for a good supply of literature has become very urgent. About one hundred years ago this need was not so urgent as at that time very few people were able to read or to appreciate books as do the present generation.

Reading is a valuable means of education and also a very pleasant one as it increases our vocabulary and helps us to express ourselves in a proper way. If a person cannot buy the books which he has to consult in the cause of his occupation, he can take pleasant refuge from the noise and turmoil of the city streets in a valuable library, there he can sit in peace and read the words of his favourite author free from all distractions. For children there is usually a special section also where they can enjoy the suitable books provided for them. Thus they are trained to love of books and reverence for literature.

We have various kinds of books dealing to all the different branches of study. Lawyers can find books containing reverence to some knotty question or other which he has to face. Horticulturist can study books relating to horticulture, the farmer can study books on agriculture, the student of history, even the astronomer, all can find books relating to numerous reverence to suit their own taste.

Were it not for reading our education would be very backward as the advantages of reading are numerous. It broadens our mind and helps us to judge and reason of our own accord. The disadvantages in comparison with the numerous advantages are very few. Reading of bad books, or neglecting of ones duties which occurs very frequent, but still it is one of the most enjoyable pastimes one can find.”

## Find and Count Game

Ooops! These books have been dropped and muddled up. Can you count how many there were of each type?

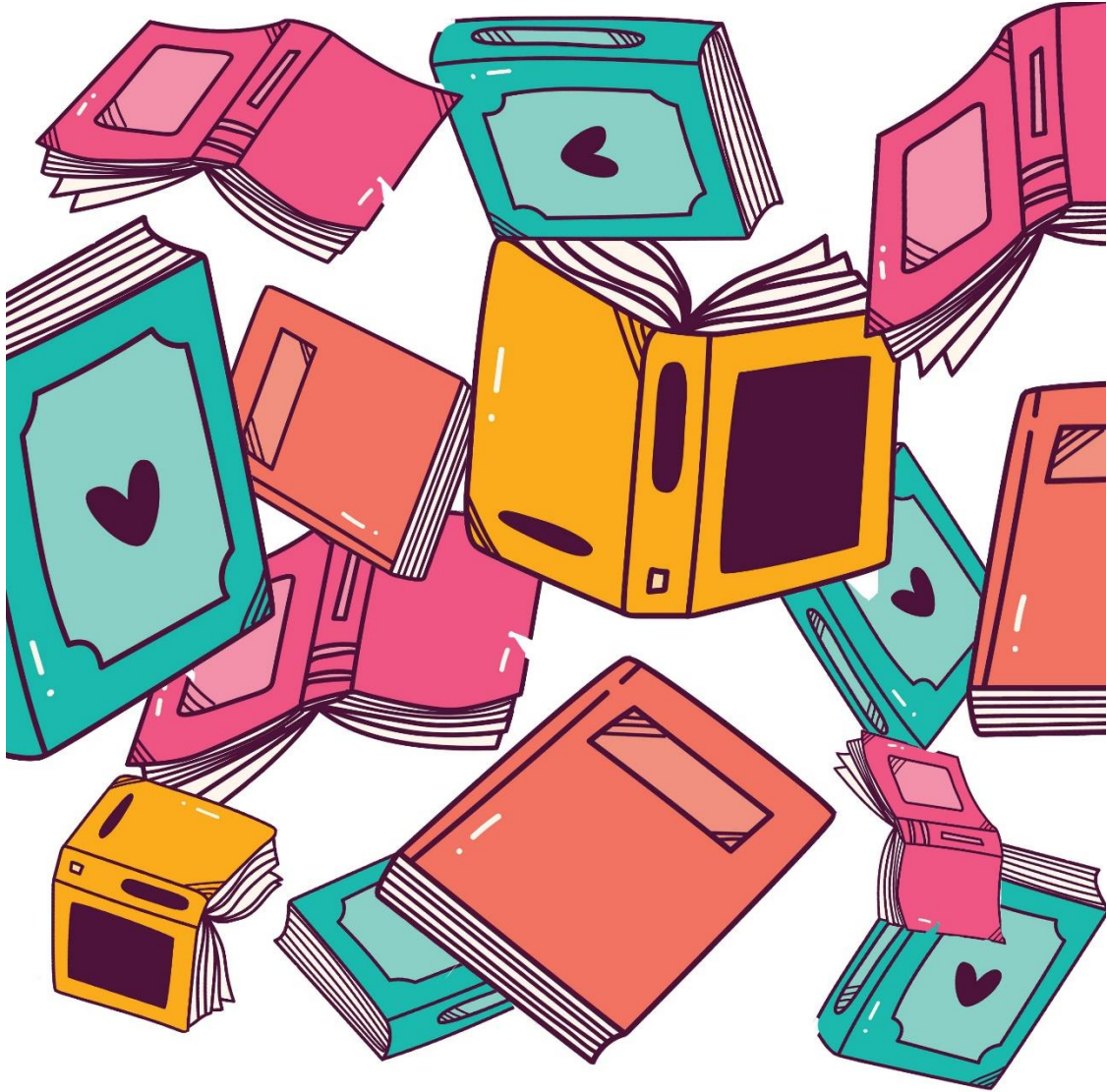

\_\_\_\_\_



\_\_\_\_\_



\_\_\_\_\_



\_\_\_\_\_

## Pictures to Colour

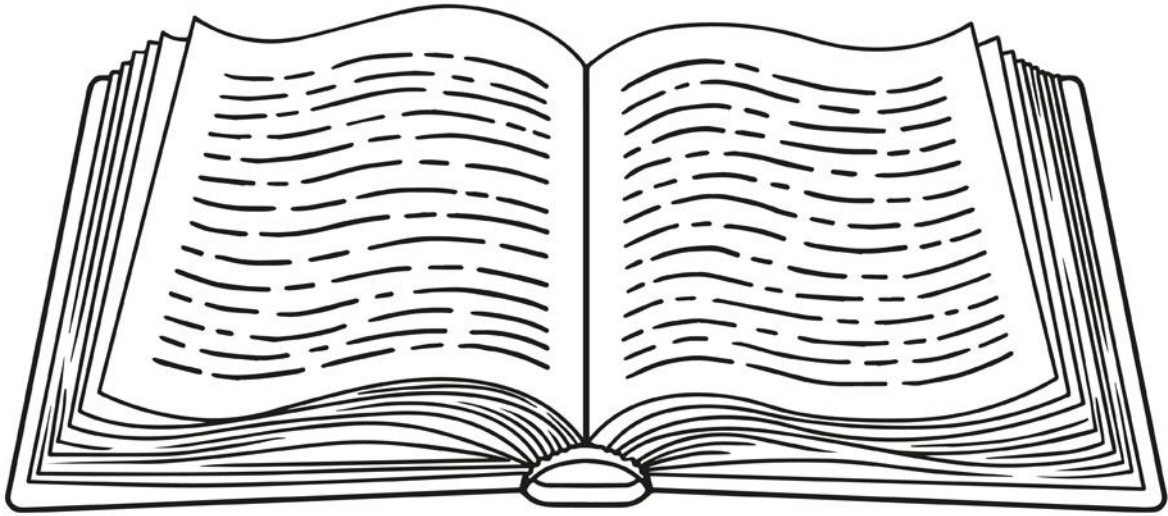

A BOOK IS A DREAM YOU HOLD IN YOUR HAND

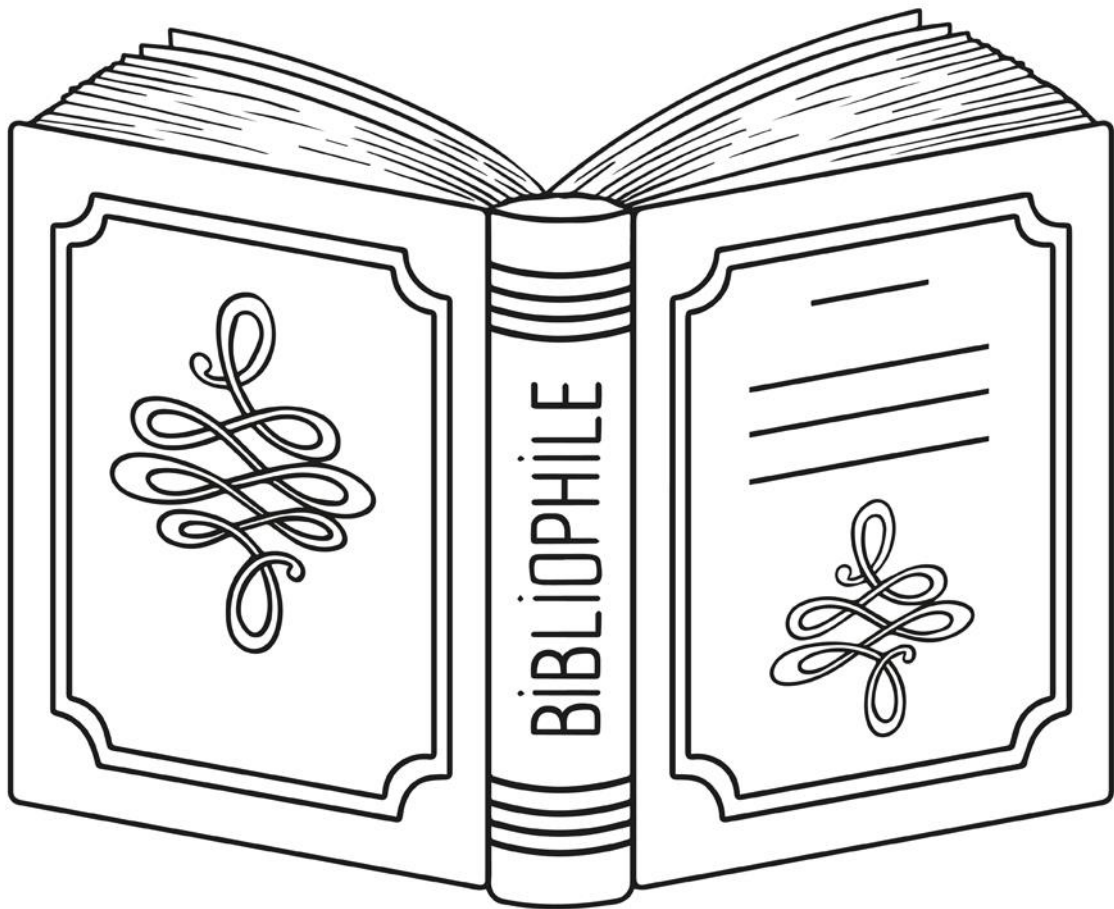

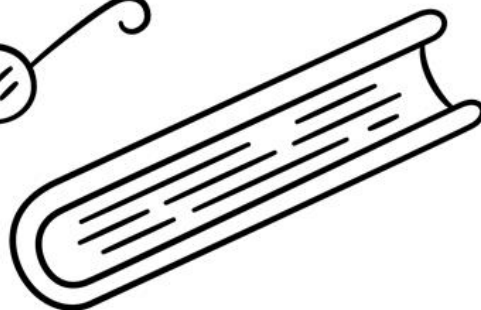
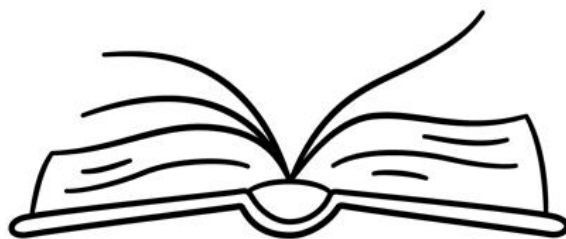
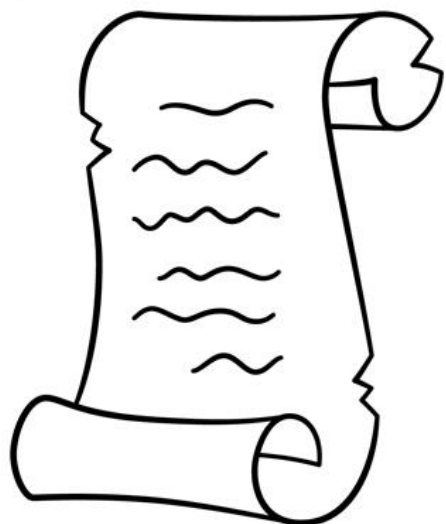
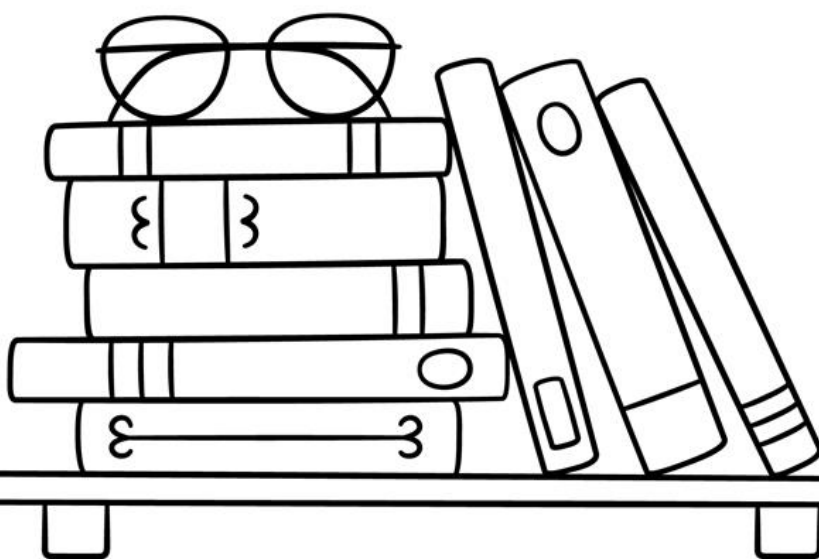
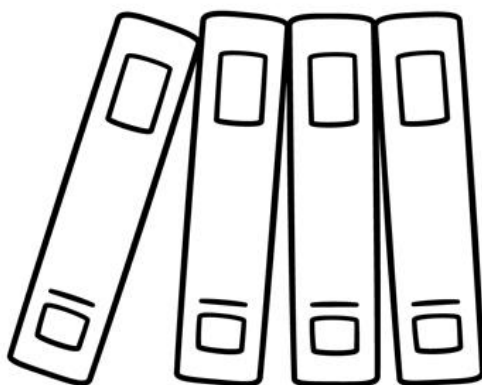
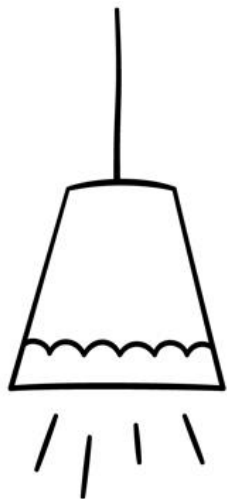

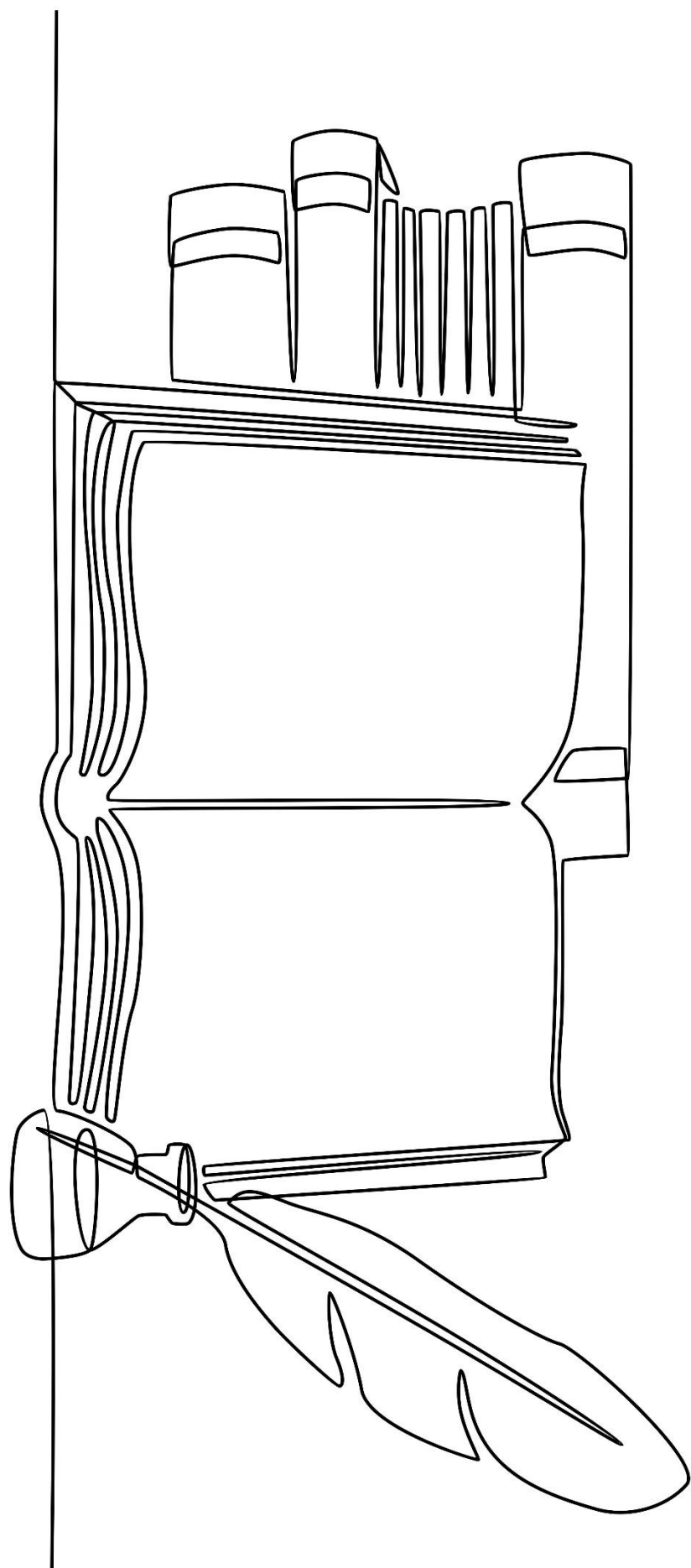

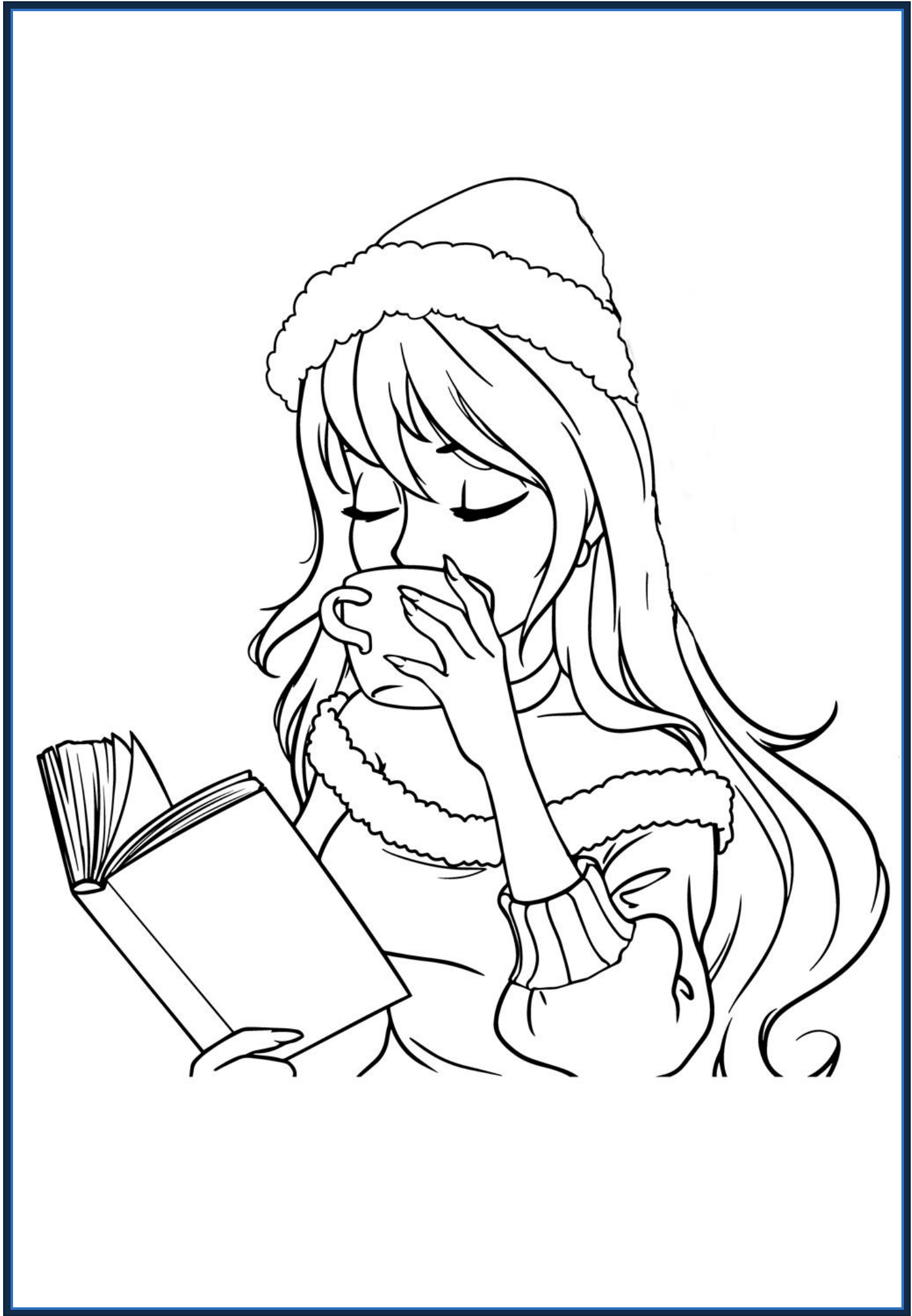

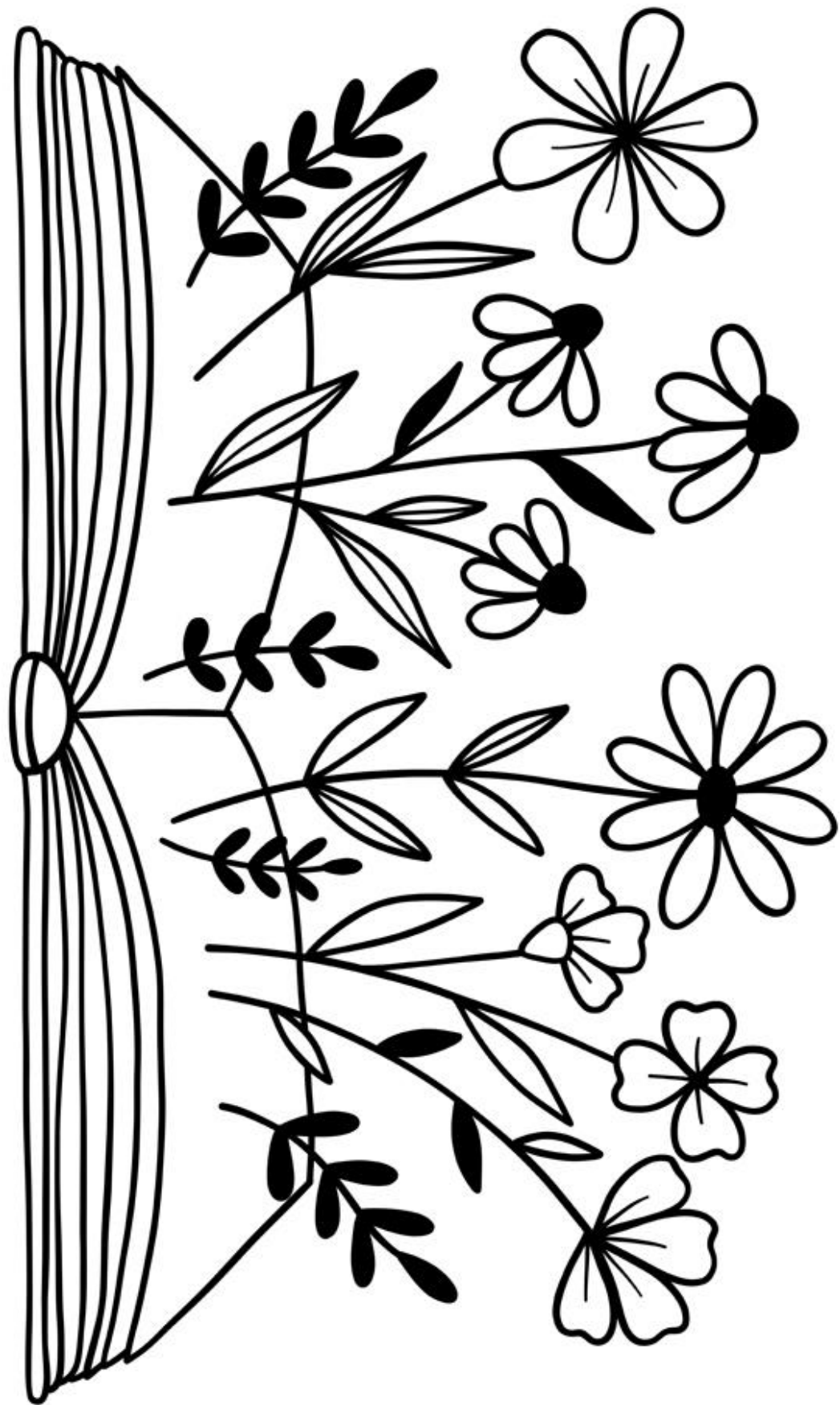

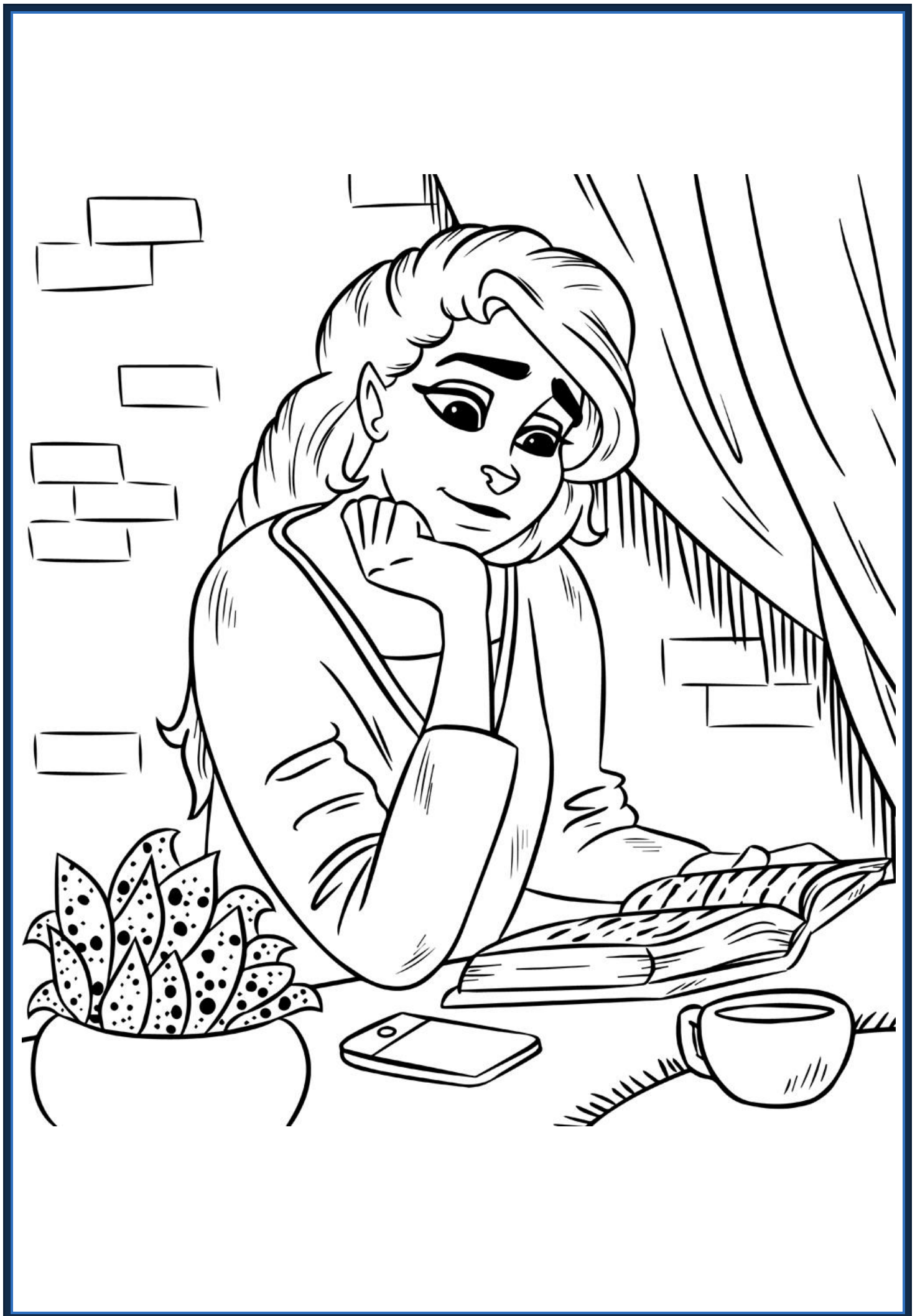

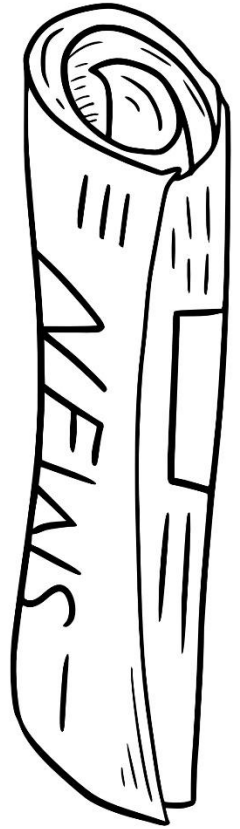

Newspaper  
Drawing

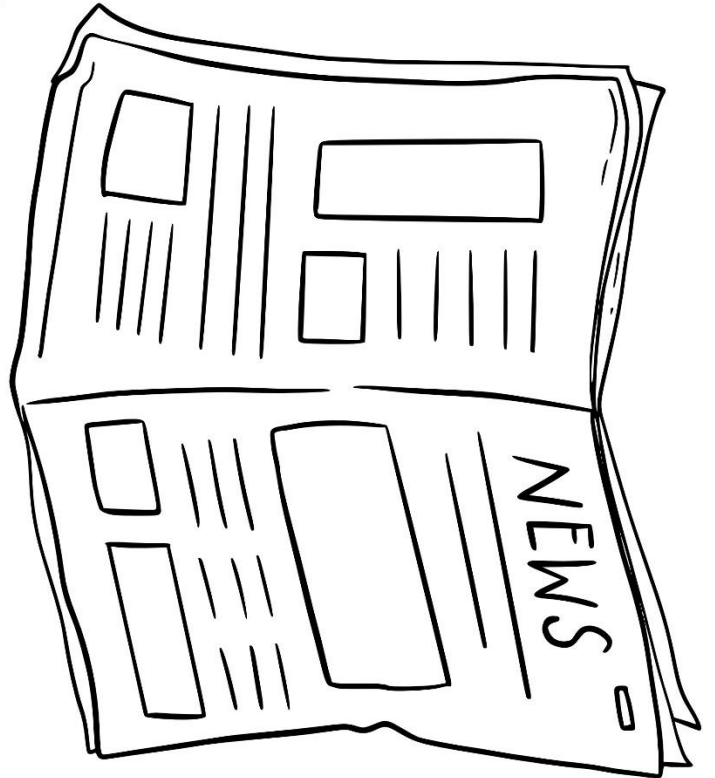
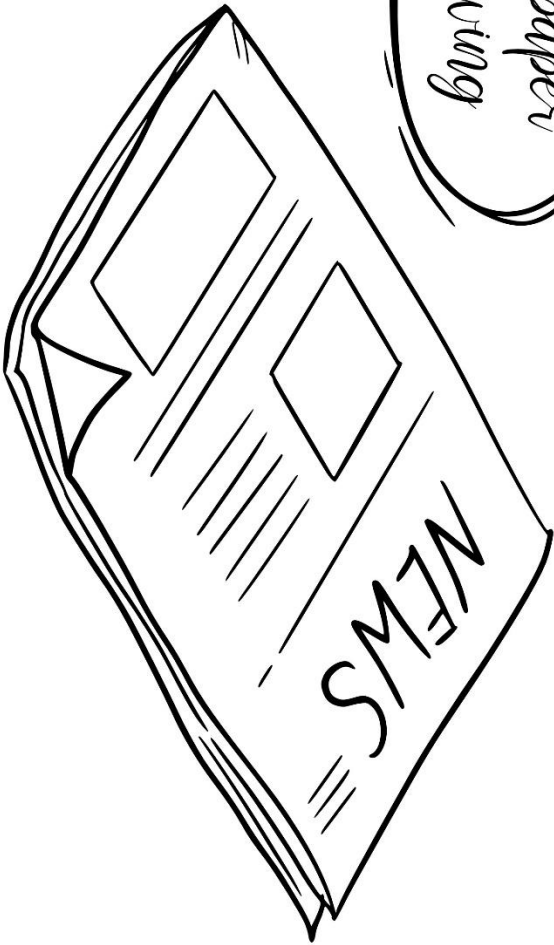

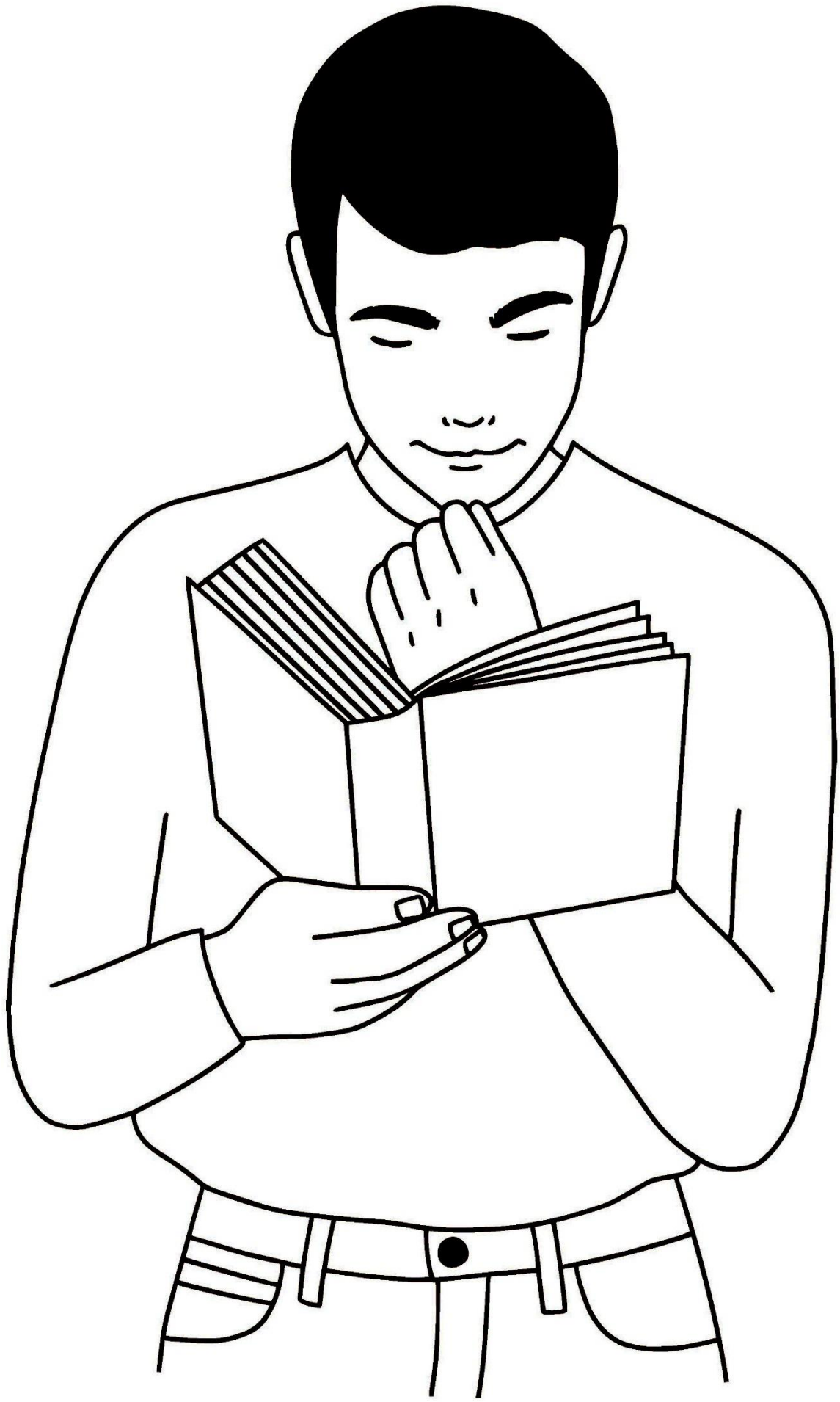

## Nostalgic Number Ones

Below is a list of number 1 songs through the years for November.  
How many to you remember and can you sing along to them?

13/11/1953	ANSWER ME	FRANKIE LAINE
19/11/1954	HOLD MY HAND	DON CORNELL
26/11/1954	THIS OLE HOUSE	ROSEMARY CLOONEY
25/11/1955	ROCK AROUND THE CLOCK	BILL HALEY & HIS COMETS
28/11/1963	SHE LOVES YOU	BEATLES
12/11/1964	OH PRETTY WOMAN	ROY ORBISON
19/11/1964	BABY LOVE	SUPREMES
28/11/1970	I HEAR YOU KNOCKING	DAVE EDMUNDS
13/11/1976	IF YOU LEAVE ME NOW	CHICAGO
05/11/1977	THE NAME OF THE GAME	ABBA
15/11/1980	THE TIDE IS HIGH	BLONDIE
05/11/1983	UPTOWN GIRL	BILLY JOEL
03/11/1990	UNCHAINED MELODY	RIGHTEOUS BROTHERS



## Bookmarks

Below are some bookmarks for you to cut out and either keep to use,  
or to give as gifts.

What type of book do you think suits each one?

Do you have a favourite, and what is your favourite book?

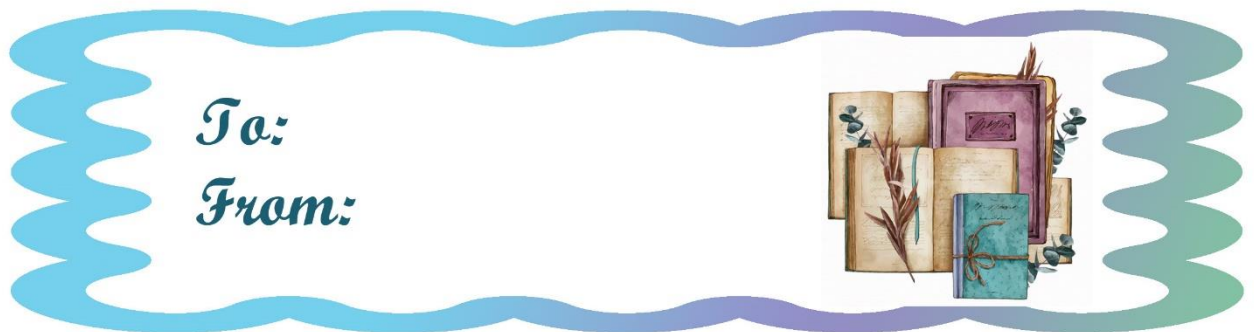

## Cailín na Gaillimhe - Galway Girl

Bhuel de thug mé cos ar an siúlóid mhór  
Thart ar lár an lae  
Is de bhuaile mé le cailín breá dathúil  
Agus thosaíó mar ag plé.

(Curfá) Agus n'fheadar liom,  
Cad a thiocfaidh orm.  
Lena gruaig chomh dubh, Is a súile gorm.  
Ach thóg mé a lámh.  
Thug mé rince di,  
Agus phóg mé cailín na Gaillimhe.

Bhíomar leath-shlí tríd nuair a d'oscail an spéir  
Níos déanaí ins an lae.  
Agus rith muid síos chuig an árasán  
Chomh bog an lae i-ay.  
(Curfá)

Bhuel de dhúisigh mé agus mé liom féin  
D'fhág sí mé i-ay  
Le mo chroí bhríste bhí pian laistigh  
Agus n'fheadar liom,  
Cad a tharlaíonn linn.  
Nuair a chasamar leis an gcailín sin  
Tá feicthe agam  
Gach uile naomh  
Ach ní a leithéid le cailín na Gaillimhe.

## I Opened a Book By Julia Donaldson

I opened a book and in I strode.  
Now nobody can find me.  
I've left my chair, my house, my road,  
My town and my world behind me.

I'm wearing the cloak, I've slipped on the ring,  
I've swallowed the magic potion.  
I've fought with a dragon, dined with a king  
And dived in a bottomless ocean.

I opened a book and made some friends.  
I shared their tears and laughter  
And followed their road with its bumps and bends  
To the happily ever after.

I finished my book and out I came.  
The cloak can no longer hide me.  
My chair and my house are just the same,  
But I have a book inside me.

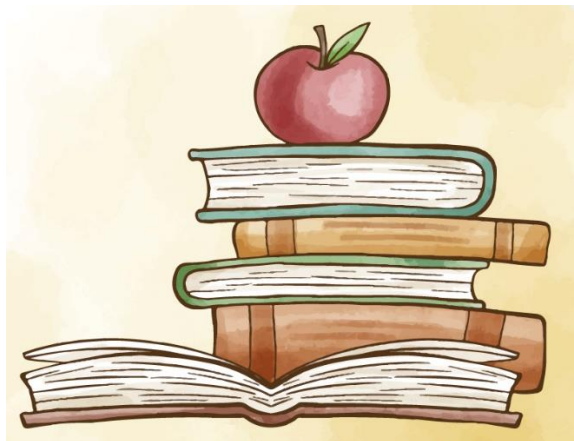

## Read to Me By Jane Yolen

Read to me riddles and read to me rhymes  
Read to me stories of magical times  
Read to me tales about castles and kings  
Read to me stories of fabulous things.

Read to me pirates and read to me knights  
Read to me dragons and dragon-book fights  
Read to me spaceships and cowboys and then  
When you are finished- please read them again.



## Clancy's Wooden Wedding

Five years ago last Sunday night when Clancy took a wife  
'twas Little Bridget Haley who would stick to him for life  
and he gave a wooden wedding the event to celebrate  
and he sent out invitations to his friends both small and great

Now everyone was supposed to bring a present made of wood  
some of the things they brought were bad and some were very good  
but everyone who came they did the very best they could  
when Clancy had a weddin' made of wood

There was all kinds of wood brought to the house that night  
hard wood, soft wood and kindling wood delight  
there was wood and wooden shavings enough to fill a bed  
'twas brought to Clancy's house when he was five years wed

Now the first one to get there was Tim O'Hoolihan,  
he brought for a present a Japanese fan  
then came Maloney just as neat as a pin  
he brought a cradle for to rock the baby in

O'Brien brought a sawhorse handsomely engraved  
O'Toole brought a cord of wood for which he didn't pay  
Murphy brought the clothespins and Ryan brought a broom  
and it looked as though a lumberyard exploded in the room

Wood that came from China, wood that came from Spain

wood from Jerusalem across the ragin' main  
wood that came from Russia sent by the Csar  
wood that came from Ireland enought to build a car  
wood that came from England, wood that came from Wales  
wood that came from Scotland, wood that came from jails  
they passed around the whiskey and they passed around the ale  
and if the glasses wasn't big enough they used a wooden pail



## Genre Jumble

Below is a list of themes and genres for books.

Using this list can you think of one book or story that fits each theme?

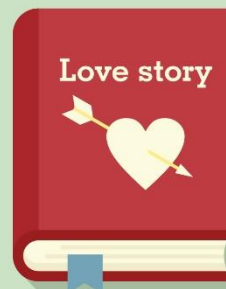

## The Meeting of the Waters by Thomas Moore

There is not in the wide world a valley so sweet  
As that vale in whose bosom the bright waters meet;  
Oh! the last rays of feeling and life must depart,  
Ere the bloom of that valley shall fade from my heart.

Yet it was not that nature had shed o'er the scene  
Her purest of crystal and brightest of green;  
'Twas not her soft magic of streamlet or hill,  
Oh! no, — it was something more exquisite still.

'Twas that friends, the beloved of my bosom, were near,  
Who made every dear scene of enchantment more dear,  
And who felt how the best charms of nature improve,  
When we see them reflected from looks that we love.

Sweet vale of Avoca! how calm could I rest  
In thy bosom of shade, with the friends I love best,  
Where the storms that we feel in this cold world should cease,  
And our hearts, like thy waters, be mingled in peace.

